



# VHD12-370W FR CASE High Discharge Rate AGM Battery

VALIANT VHD ( High Rate ) series Valve Regulated Lead Acid (VRLA) battery is designed for heavy load discharge applications with over 8 years design life in float service. By using strong grids, thick plate and specially designed active material. It is with lower I.R, lower self discharge rate, high power, and longer service life. The VHD series battery offers 30% more power output than the standard series. It is suitable for high power standby used, such as datacenter, UPS, EPS etc.

**12V  
370W**

**AGM  
Technology**

**High Rate  
Discharge**



**COMPLIED STANDARDS**

**IEC 60896-21/22      JIS C8704  
YD/T799              BS6290 part4  
GB/T 19638              CE**

**Applications**

- UPS & EPS
- Emergency lighting Systems
- Medical Equipment
- The office computer
- Alarm Systems

**General Features**

- Thicker plate with high Tin low Calcium alloy
- High Reliability and Good Quality
- Deep Discharge Recovery
- High Power Density
- Longer Service Life, in both Float or Cyclic

**Dimensions & Weight**

Length(mm/inch)	260/10.24
Width(mm/inch)	169/6.65
Height(mm/inch)	211/8.31
Total Height(mm/inch)	215/8.46
Weight(kg/lbs)(±3%)	31/68.33

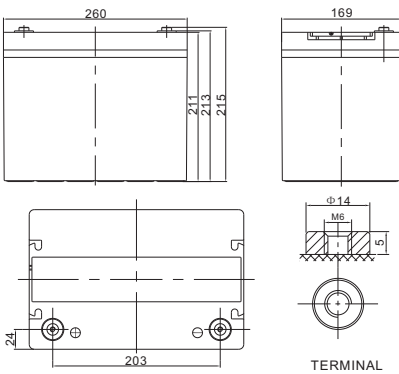

**Technical Specifications**

Nominal Voltage		12V (6 cells per unit)
Design Floating Life @ 25°C		10 Years
Watts/cell @ 25°C	@15min, 1.67V	370W
Capacity @ 25°C	10 hour rate (9.5A, 10.8V)	95.0Ah
	5 hour rate (16.6A, 10.5V)	83.0Ah
	1 hour rate (63.8A, 9.6V)	63.8Ah
Internal Resistance	Full Charged Battery@ 25°C	≤5.0mΩ
Ambient Temperature	Discharge	-15°C ~ 45°C
	Charge	-15°C ~ 45°C
	Storage	-15°C ~ 45°C
Max.Discharge Current @ 25°C		570A ( 5s )
Capacity affected by Temperature (10 hour )	40°C	102%
	25°C	100%
	0°C	85%
	-15°C	65%
Self-Discharge@25°C per Month		3%
Charge (Constant Voltage) @ 25°C	Standby Use	Initial Charging Current Less than 19.0A Voltage 13.6-13.8V
	Cycle Use	Initial Charging Current Less than 19.0A Voltage 14.4-14.9V

**Battery Discharge Table**

**Discharge Constant Current per Cell (Amperes at 25°C)**

F.V/Time	5min	10min	15min	20min	25min	30min	45min	60min	90min	2h	3h	10h
1.60V	290.5	229.9	201.7	176.5	150.5	126.5	91.9	63.8	53.3	40.4	29.2	10.45
1.67V	285.1	225.7	198.0	174.3	147.7	124.1	90.3	62.6	52.4	39.7	28.7	10.21
1.70V	279.9	221.5	194.4	171.1	145.0	121.8	88.6	61.4	51.3	38.8	28.1	10.09
1.75V	274.6	217.4	190.7	165.7	142.3	119.6	86.9	60.3	50.3	38.1	27.7	9.86
1.80V	264.1	209.0	183.4	158.7	136.8	115.0	83.6	58.0	48.5	36.7	26.6	9.50

**Discharge Constant Power per Cell (Watts at 25°C)**

F.V/Time	5min	10min	15min	20min	25min	30min	45min	60min	90min	2h	3h	10h
1.60V	541.8	428.7	376.1	329.2	280.7	235.9	171.4	118.9	99.4	75.3	54.5	19.5
1.67V	531.8	420.9	370.0	325.1	275.4	231.4	168.3	116.7	97.7	74.0	53.6	19.0
1.70V	522.0	413.1	362.6	319.1	270.4	227.2	165.2	114.5	95.6	72.4	52.5	18.8
1.75V	512.1	405.4	355.7	309.0	265.4	223.0	162.1	112.5	93.9	71.1	51.6	18.4
1.80V	492.5	389.8	341.9	295.9	255.1	214.4	155.9	108.1	90.4	68.4	49.6	17.7



## Performance Characteristics

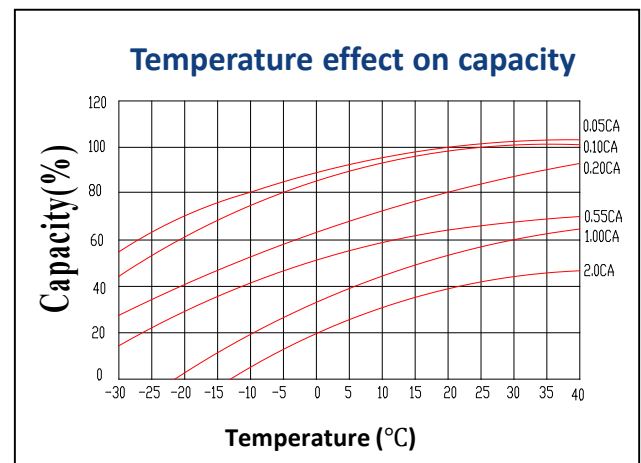
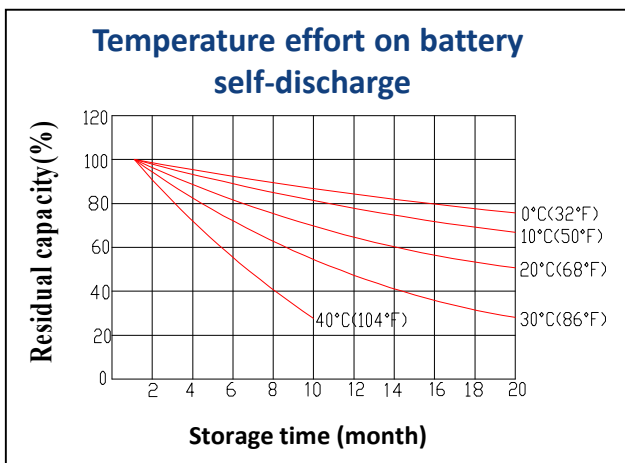
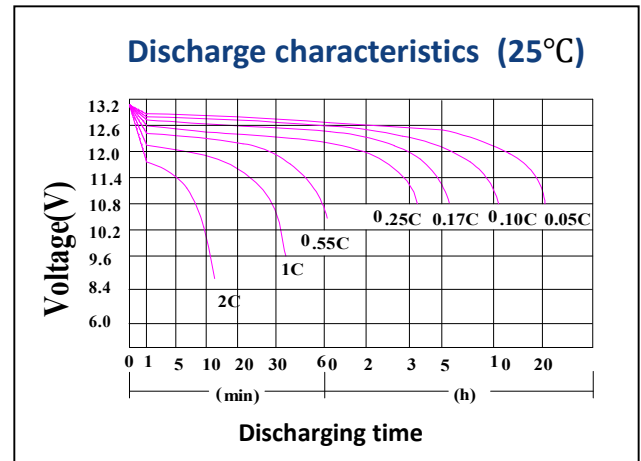
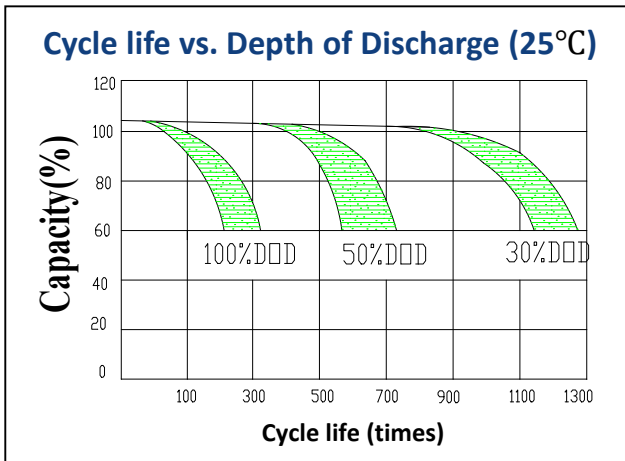
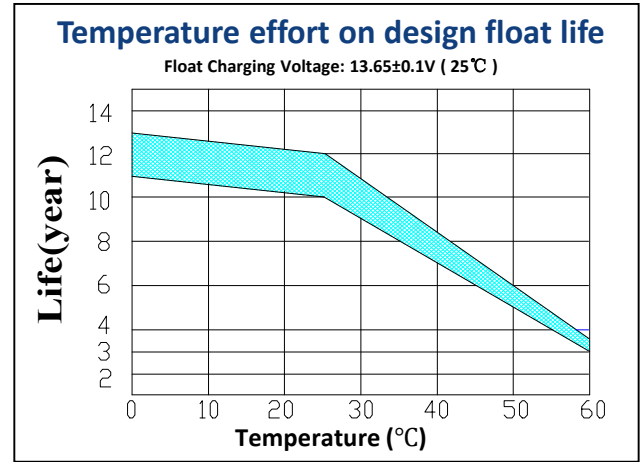
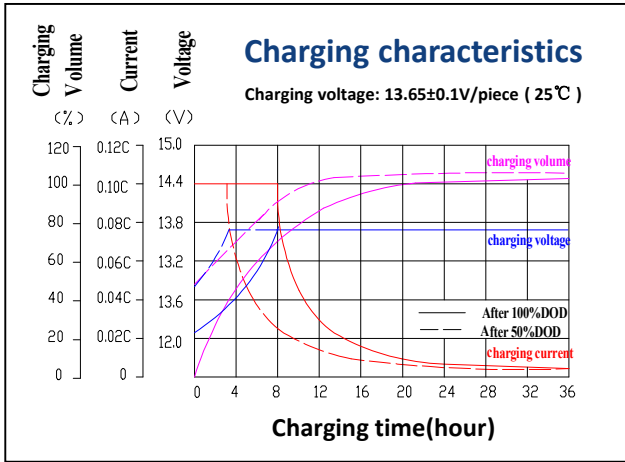

## Battery Construction

Component	Positive Plate	Negative Plate	Container & Cover	Safety Valve	Terminal	Separator	Electrolyte	Pillar Seal
Features	Thick high Sn low Ca grid with special paste	Balanced Pb-Ca grid for improved recombination efficiency	Fire resistant ABS (UL94-V0 optional)	Flame Si-Rubber and aging resistant	Female Copper Insert M6	Advanced AGM separator for high pressure cell design	Dilute high purity sulfuric acid	Two layers epoxy resin seal