



VTD12-100 (12V 100AH/20HR) Deep Cycle AGM Battery

The Valiant VTD series deep cycle AGM battery features special additives to the positive plate and advanced AGM separators which increase cycle life up to 70% higher compared with standard AGM batteries. This technology also provides up to 15 years of float life. The VTD series is highly suited for systems that rely heavily on battery storage power such as off-grid solar systems, RV and marine and electric vehicles.

**12V
100Ah**

**AGM
Technology**

**Deep
Cycle**



Applications

- Off-grid solar systems
- RV and marine
- UPS/Telecom
- Electric vehicle
- Golf cart

General Features

- Thicker plate with high Tin low Calcium alloy
- Deep discharge recovery, 1200cycle @50% DOD
- 2 years full warranty in most applications
- Longer Service Life, in both Float or Cycling applications
- High Power Density

Dimensions & Weight

Length(mm/inch)	307/12.08
Width(mm/inch)	169/6.65
Height(mm/inch)	211/8.31
Total Height(mm/inch)	216/8.50
Weight(kg/lbs)(±3%)	30.2/67.2

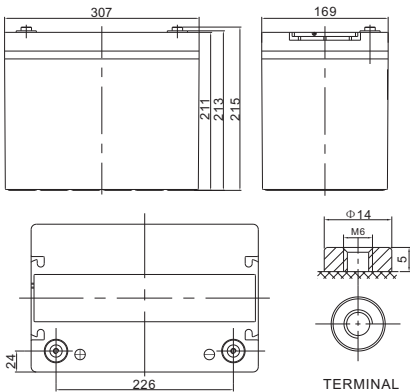

Technical Specifications

Nominal Voltage		12V (6 cells per unit)
Design Floating Life @ 25°C		15 Years
Nominal Capacity @ 25°C	20 hour rate@5.0A,10.8V	100Ah
Capacity @ 25°C	10 hour rate (9.0A, 10.8V)	90Ah
	5 hour rate (15.9A, 10.5V)	79.5Ah
	1 hour rate (55.6A, 9.6V)	55.6Ah
Internal Resistance	Full Charged Battery@ 25°C	≤6.0mΩ
Ambient Temperature	Discharge	-15°C~45°C
	Charge	-15°C~45°C
	Storage	-15°C~45°C
Max.Discharge Current		@ 25°C 540A(5s)
Capacity affected by Temperature (10 hour)	40°C	105%
	25°C	100%
	0°C	85%
	-15°C	65%
Self-Discharge@25°C per Month		3%
Charge (Constant Voltage) @ 25°C	Standby Use	Initial Charging Current Less than 25.0A Voltage 13.6-13.8V
	Cycle Use	Initial Charging Current Less than 25.0A Voltage 14.4-14.9V



COMPLIED STANDARDS
 IEC 60896-21/22 JIS C8704
 YD/T799 BS6290 part4
 GB/T 19638 CE

Battery Discharge Table

Discharge Constant Current per Cell (Amperes at 25°C)

F.V/Time	15min	30min	45min	1h	2h	3h	5h	8h	10h	20h	100h
1.60V	128.7	82.0	60.5	55.6	35.3	24.8	16.8	11.1	9.9	5.4	1.20
1.65V	126.4	80.5	59.4	54.5	34.6	24.3	16.5	10.9	9.7	5.3	1.18
1.70V	124.0	79.0	58.3	53.5	34.0	23.9	16.2	10.7	9.5	5.2	1.15
1.75V	121.7	77.5	57.2	52.5	33.3	23.4	15.9	10.5	9.4	5.1	1.13
1.80V	117.0	74.5	55.0	50.5	32.1	22.5	15.3	10.1	9.0	5.0	1.11

Discharge Constant Power per Cell (Watts at 25°C)

F.V/Time	15min	30min	45min	1h	2h	3h	5h	8h	10h	20h	100h
1.60V	247.7	157.8	116.5	106.9	67.9	47.6	32.4	21.4	19.1	10.4	2.31
1.65V	243.2	154.9	114.3	105.0	66.6	46.8	31.8	21.0	18.7	10.2	2.26
1.70V	238.7	152.0	112.2	103.0	65.4	45.9	31.2	20.6	18.4	10.0	2.22
1.75V	234.2	149.1	110.1	101.1	64.2	45.0	30.6	20.2	18.0	9.8	2.18
1.80V	225.2	143.4	105.9	97.2	61.7	43.3	29.5	19.4	17.3	9.6	2.14



Performance Characteristics

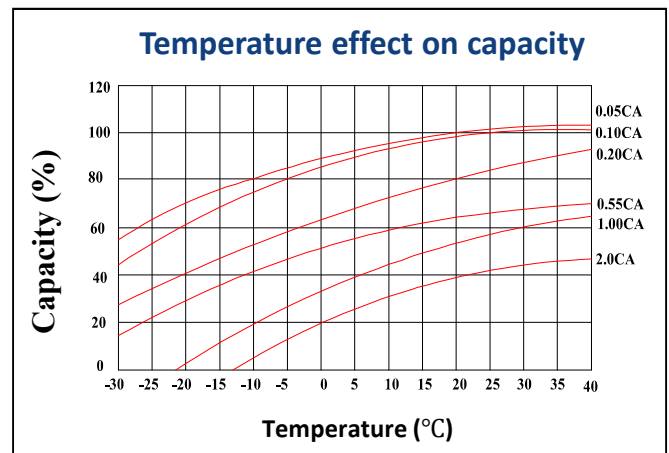
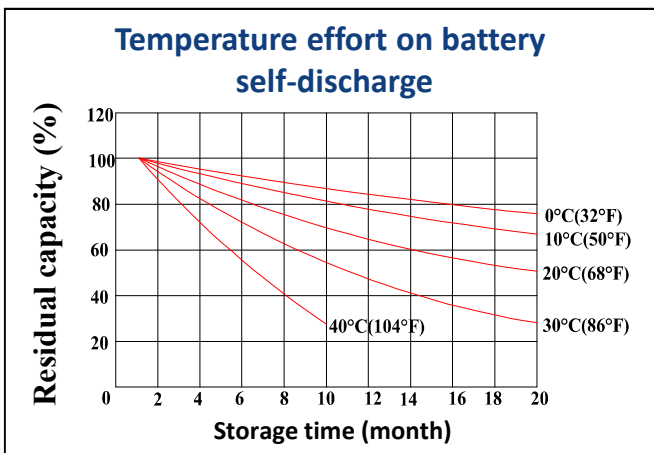
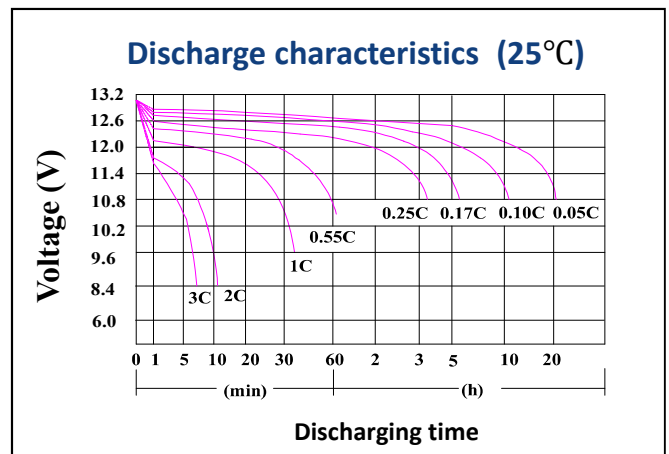
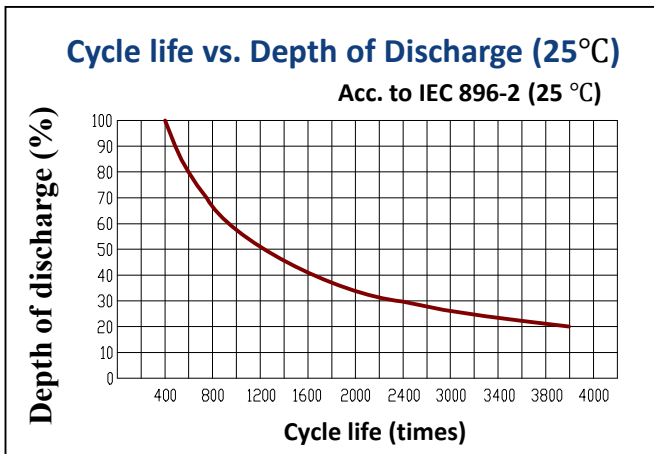
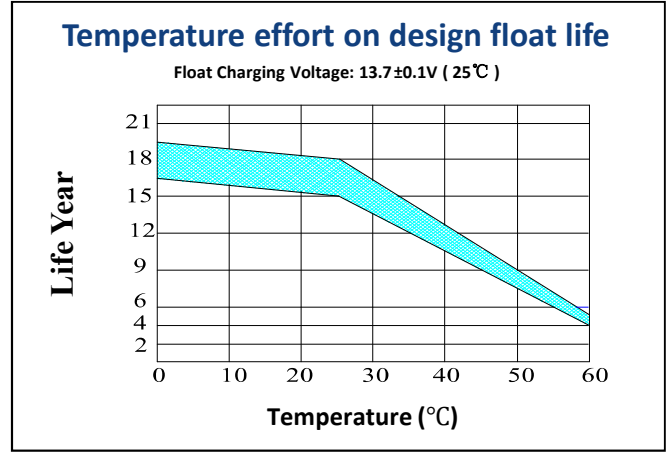
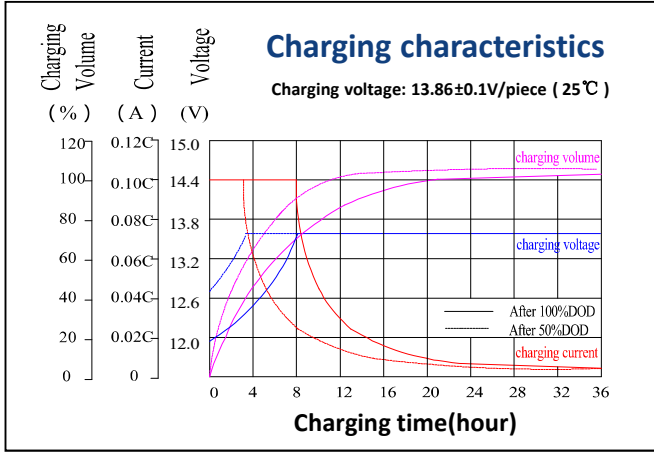

Battery Construction

Component	Positive Plate	Negative Plate	Container & Cover	Safety Valve	Terminal	Separator	Electrolyte	Pillar Seal
Features	Thick high Sn low Ca grid with special paste	Balanced Pb-Ca grid for improved recombination efficiency	ABS (UL94-VO optional)	Flame Si-Rubber and aging resistant	M6	Advanced AGM separator for high pressure cell design	Dilute high purity sulfuric acid	Two layers epoxy resin seal