



VTG12-20 (12V 20AH/20HR) High Temperature Deep Cycle GEL Battery

The Valiant VTG series deep cycle Gel battery uses an advanced nano gel electrolyte with Super-C additive and heavy-duty plate design to provide longer service life in deep cycle applications. The VTG series provides optimum and reliable service under extreme temperatures and frequent power failures making it highly suited for out door applications such as off-grid solar systems, RV, and telecom/UPS systems.

**12V
20Ah**

**GEL
Technology**

**Deep
Cycle**



Applications

- Off-grid solar systems
- RV and Marine
- UPS/Telecom
- Floor Scrubber
- Wheel chair, Golf cart

General Features

- Operating range of -40 to+ 60 °C
- Deep discharge recovery,1600 cycles @50%DOD
- 2-3 year full warranty in most applications
- Longer life and greater stability in extreme temperatures

Dimensions & Weight

Length(mm/inch)	181/7.13
Width(mm/inch)	77/3.03
Height(mm/inch)	167/6.58
Total Height(mm/inch)	167/6.58
Weight(kg/lbs)(±3%)	6.0/13.2

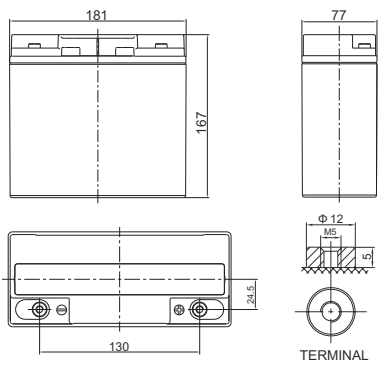

Technical Specifications

Nominal Voltage		12V (6 cells per unit)
Design Floating Life @ 25°C		8 Years
Nominal Capacity @ 25°C	20 hour rate@1.0A,10.8V	20Ah
Capacity @ 25°C	10 hour rate (1.8A, 10.8V)	18Ah
	5 hour rate (3.2A, 10.5V)	16Ah
	1 hour rate (11.1A,9.6V)	11.1Ah
Internal Resistance	Full Charged Battery@ 25°C	≤12.0mΩ
Ambient Temperature	Discharge	-25°C ~ 45°C
	Charge	-25°C ~ 45°C
	Storage	-25°C ~ 45°C
Max.Discharge Current		@ 25°C 120A(5s)
Capacity affected by Temperature (10 hour)	40°C	108%
	25°C	100%
	0°C	90%
	-15°C	70%
Self-Discharge@25°C per Month		3%
Charge (Constant Voltage) @ 25°C	Standby Use	Initial Charging Current Less than 6.0A Voltage 13.6-13.8V
	Cycle Use	Initial Charging Current Less than 6.0A Voltage 14.4-14.9V



COMPLIED STANDARDS
IEC 60896-21/22 **JIS C8704**
YD/T799 **BS6290 part4**
GB/T 19638 **CE**

Battery Discharge Table

Discharge Constant Current per Cell (Amperes at 25°C)

F.V/Time	15min	30min	45min	1h	2h	3h	5h	8h	10h	20h	100h
1.60V	25.7	16.4	12.1	11.1	7.0	5.0	3.4	2.2	2.0	1.1	25.7
1.65V	25.3	16.1	11.9	10.9	6.9	4.9	3.3	2.2	1.9	1.08	25.3
1.70V	24.8	15.8	11.6	10.7	6.8	4.8	3.2	2.1	1.9	1.06	24.8
1.75V	24.3	15.5	11.4	10.5	6.7	4.7	3.2	2.1	1.9	1.04	24.3
1.80V	23.4	14.9	11	10.1	6.4	4.5	3.1	2.0	1.8	1.00	23.4

Discharge Constant Power per Cell (Watts at 25°C)

F.V/Time	15min	30min	45min	1h	2h	3h	5h	8h	10h	20h	100h
1.60V	74.7	45.5	30.5	28.2	16.3	11.4	7.8	5.1	4.6	2.5	0.55
1.65V	73.3	44.7	29.9	27.7	16.0	11.2	7.6	5.0	4.5	2.4	0.54
1.70V	72.0	43.8	29.4	27.2	15.7	11.0	7.5	4.9	4.4	2.4	0.53
1.75V	70.6	43.0	28.8	26.7	15.4	10.8	7.4	4.9	4.3	2.4	0.52
1.80V	67.9	41.3	27.7	25.6	14.8	10.4	7.1	4.7	4.2	2.3	0.51



Performance Characteristics

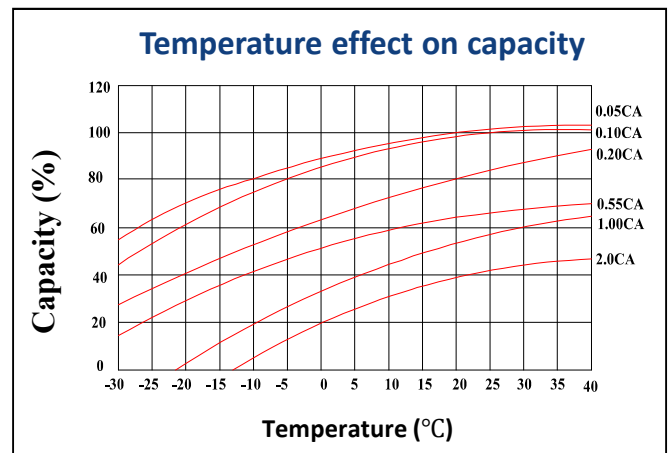
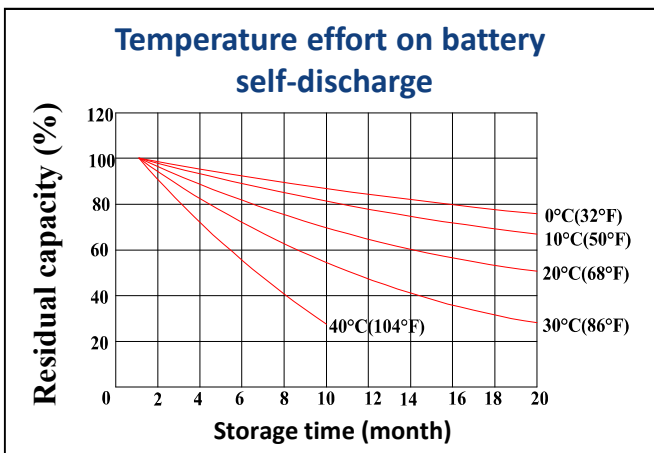
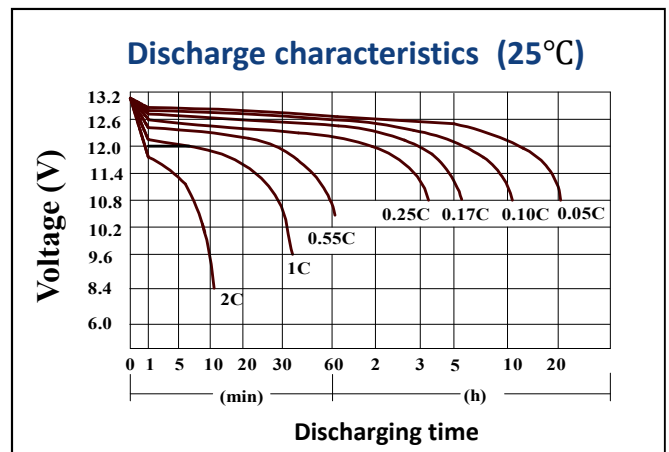
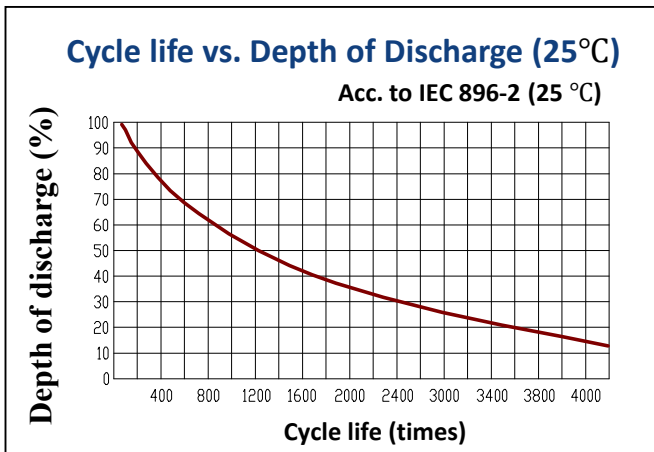
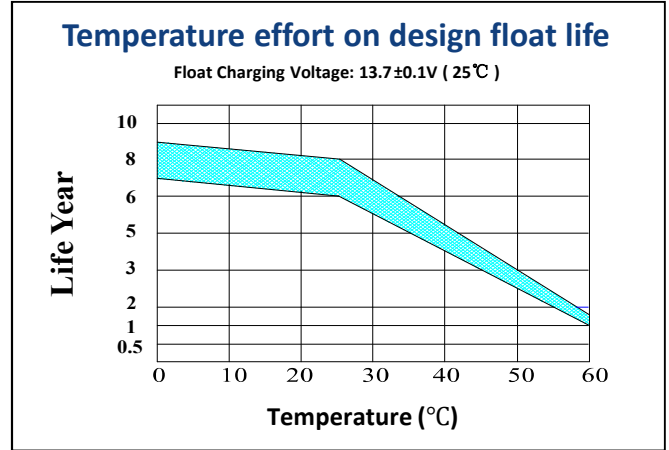
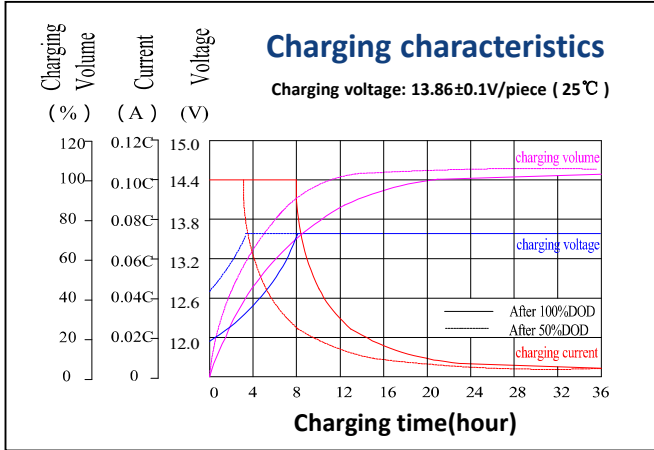

Battery Construction

Component	Positive Plate	Negative Plate	Container & Cover	Safety Valve	Terminal	Separator	Electrolyte	Pillar Seal
Features	Thick high Sn low Ca grid with special paste	Balanced Pb-Ca grid for improved recombination efficiency	Fire resistant ABS (UL94-V0 optional)	Flame Si-Rubber and aging resistant	Female Copper Insert M5	Advanced AGM separator for high pressure cell design	Silicon Gel	Two layers epoxy resin seal