

**GROUP 24**

**BG24**



**SNAP-TOP BATTERY BOX.**

**ULTIMATE PROTECTION.**

**IMPACT RESISTANT**  
DOWN TO -20°F.

**RESISTANT TO**  
ACID, GAS, OIL, UV.



**NOCO**

30339 Diamond Parkway, #102  
Glenwillow, OH 44139 | USA  
1.800.456.6626

no.co

# ALL NEW DESIGN.

**REINFORCED  
STRUCTURE.**

**IMPROVED  
LOCKING TABS.**

**HEAVY-DUTY  
HANDLES.**

**EASY INSTALLATION.  
MULTIPLE OPTIONS FOR INSTALLATION.**

# MAXIMUM VERSATILITY.

**MULTIPLE CABLE PORTS.**

Multiple cable ports offer easy installation for a variety of applications.



## OPTION 1: DIRECT MOUNT

Use predetermined mounting locations to fasten box directly to mounting surface.

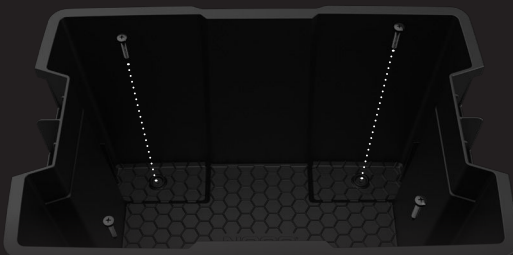

## OPTION 2: STRAP MOUNT

**STEP 1**  
Fasten mounting plate to desired location.

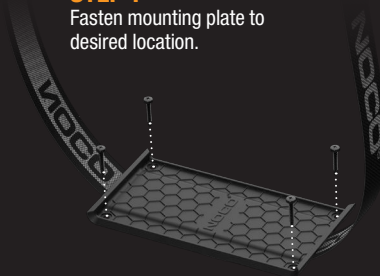

## STEP 2

Use strap to fasten box to mounting tray.



## WHAT'S IN THE BOX

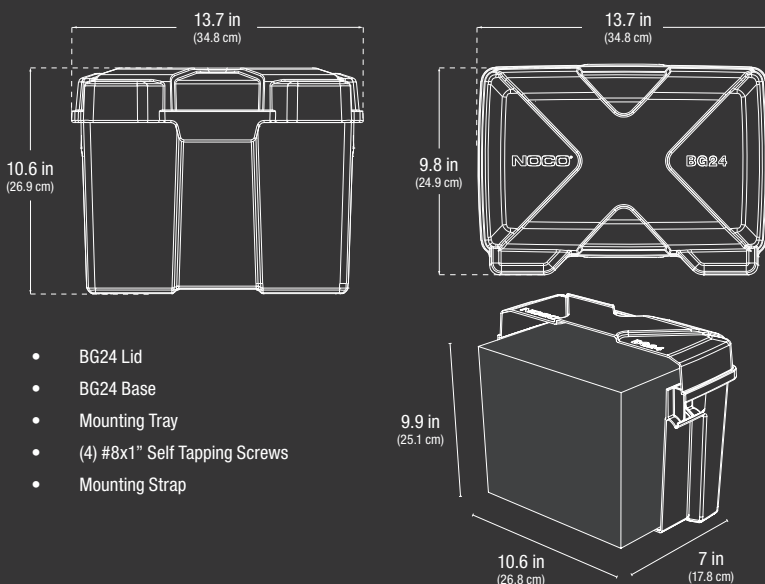

## TECHNICAL SPECIFICATIONS

<b>BATTERY GROUP:</b>	Group 24												
<b>WEIGHT:</b>	2.33 lbs (1.06kg)												
<b>CERTIFICATIONS:</b>	<ul style="list-style-type: none"> <li>• Meets Coast Guard (USCG) Code of Federal Regulations 183.420.</li> <li>• Meets American Boat and Yacht Council (ABYC) E-10.7.</li> </ul>												
<b>VOLUMETRICS:</b>	<table border="0"> <tr> <td><b>Retail Packaging:</b></td> <td><b>Master Carton:</b></td> </tr> <tr> <td>Dimensions: 13.70" x 9.90" x 10.60"</td> <td>Dimensions: 13.88" x 10.13" x 33.13"</td> </tr> <tr> <td>Weight: 3.10 lbs</td> <td>Weight: 15.55 lbs</td> </tr> <tr> <td>UPC: 00046221220094</td> <td>Quantity: 6</td> </tr> <tr> <td></td> <td>UCC: 10046221220091</td> </tr> <tr> <td></td> <td><b>Units Per Pallet:</b> 150 Units</td> </tr> </table>	<b>Retail Packaging:</b>	<b>Master Carton:</b>	Dimensions: 13.70" x 9.90" x 10.60"	Dimensions: 13.88" x 10.13" x 33.13"	Weight: 3.10 lbs	Weight: 15.55 lbs	UPC: 00046221220094	Quantity: 6		UCC: 10046221220091		<b>Units Per Pallet:</b> 150 Units
<b>Retail Packaging:</b>	<b>Master Carton:</b>												
Dimensions: 13.70" x 9.90" x 10.60"	Dimensions: 13.88" x 10.13" x 33.13"												
Weight: 3.10 lbs	Weight: 15.55 lbs												
UPC: 00046221220094	Quantity: 6												
	UCC: 10046221220091												
	<b>Units Per Pallet:</b> 150 Units												

**NOCO**

30339 Diamond Parkway, #102  
Glenwillow, OH 44139 | USA  
1.800.456.6626

no.co